

Lake House

A Foundation Paper Piecing Quilt Pattern from Tiny Llama Quilts



Skill Level: Confident Beginner | Intermediate

[#lakehousequilt](#)

© Nika Gordham of Tiny Llama Quilts
Duplication or redistribution is prohibited



Cover Fabrics

This quilt uses nine different 1/2 yard cuts of fabric in different colors or prints to create a scrappy look. All color fabrics in the cover quilt are from the Suzy Quilts Signature Pure Solids collection from Art Gallery Fabrics. Fabric colors used for the cover quilt are:

| | | |
|---|---|---|
|  Ginger (1) |  Honeymoon (4) |  Velvet (7) |
|  Shrimpy (2) |  Nova (5) |  Pearl (8) |
|  Cerulean (3) |  Monet (6) |  Queen Bee (9) |

Fabric Requirements

| Fabric Requirements: Yardage Version | | Fabric Requirements: FQ Version | |
|--------------------------------------|---------------|---|--|
| Colors/Prints 1-9 | 1/2 yard each | <p>**This quilt can be made with fat quarters for maximum scrappiness. You will need 18 fat quarters in different colors/prints to make the fat quarter version.</p> <p>Fabric requirements for background fabric, backing, and binding will be the same for both versions.</p> | |
| Background Fabric | 2 yards | | |
| Backing (4" overage) | 4 yards | | |
| Binding (2 1/2" strips) | 1/2 yard | | |

Finished quilt size: 54" x 60"

Before You Begin

Read through the entire pattern before you start to avoid any surprises.

A 1/4" seam allowance is indicated throughout the pattern and is required for accurate piecing.

Fabric requirements are based on an assumption of a 42" width of fabric.

Abbreviations:

WOF = Width of Fabric
Rec = Rectangle

RST = Right Sides Together
Sq = Square

Before You Begin Cont.

This pattern does not include written instructions on how to do the foundation paper piecing technique. There are many excellent resources available online that teach this technique. If you would like some recommendations on comprehensive resources, shout me out on Instagram @tinylamaquilts or send me an email at nika@tinylamaquilts and I will recommend some for you :)

IMPORTANT:

Print settings: When printing FPP templates, be sure to print each page at Actual Size 100%. Do not select "Print to fit" or "Fill Page".

With each template page that you print, be sure to measure the 1" square with a quilt ruler to ensure that the square measures exactly one inch:

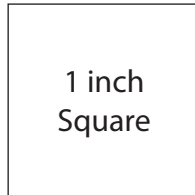

Each house block is divided into (4) parts. To complete one house block, piece each part separately and then combine them. Just follow the numbers, starting with 1A and ending with 17E. There are a total of (9) house blocks in this quilt and every house block is a different combination of colors.

When making a house block, it is important to remember that all of the A's should be the same color/print for that specific house block, all of the B's should be the same color/print for that specific house block, all of the C's should be the same color/print for that specific house block, and so on, as in each house block, the color A represents the sky, the color B represents the chimney, the color C represents the roof, etc.

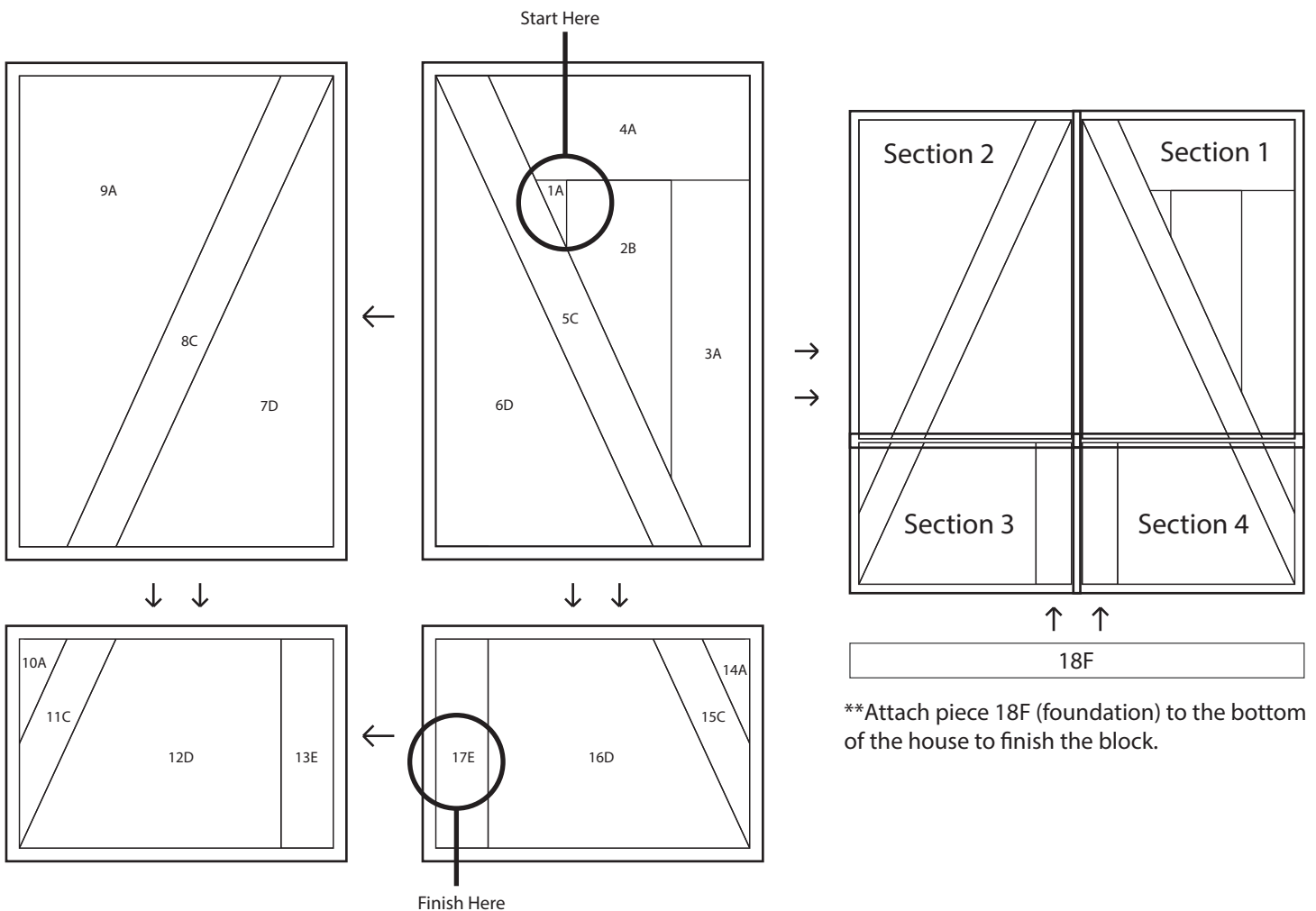

Yardage Version Cutting Diagram

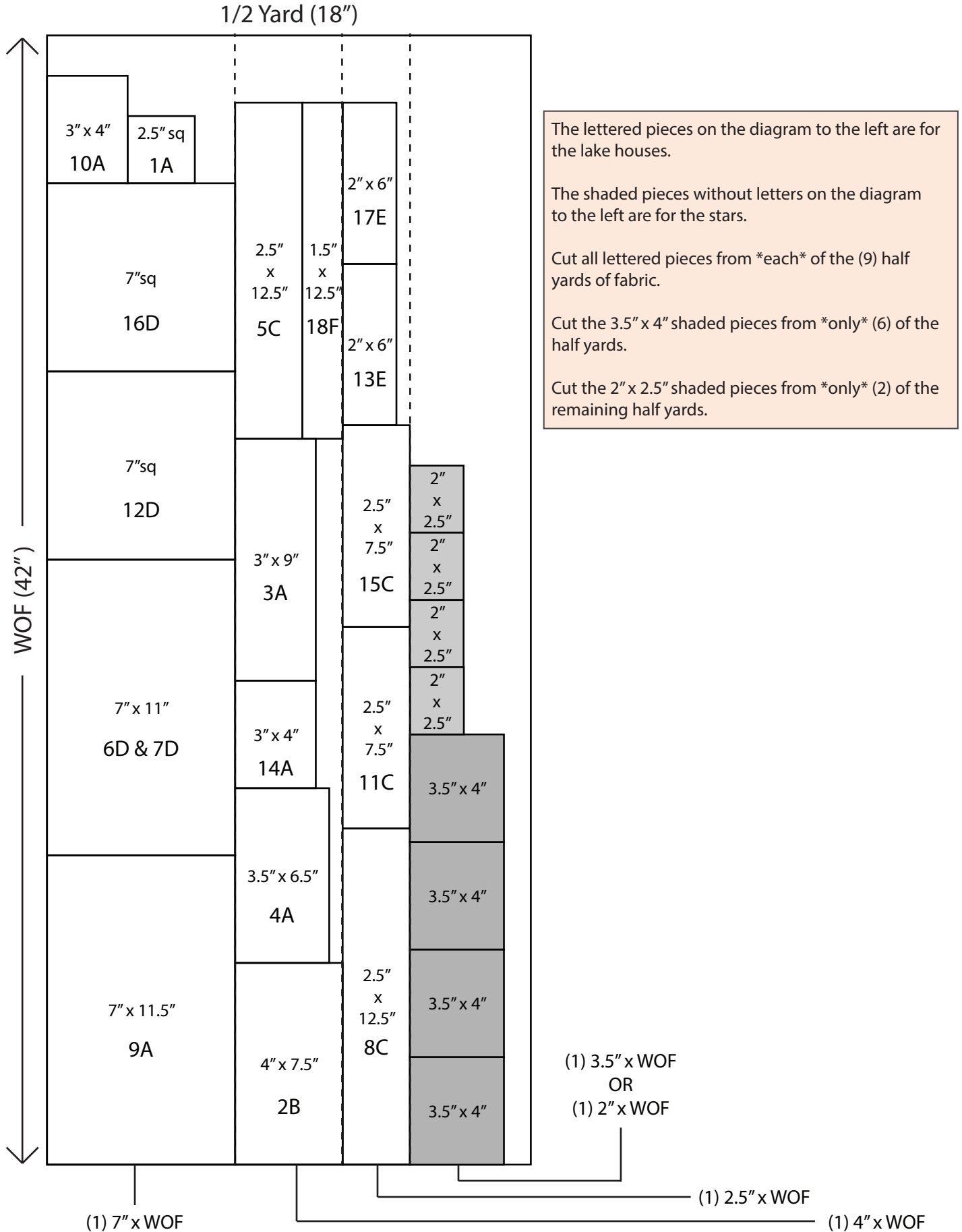

FQ Version Cutting Diagram

FQ's 1 - 9

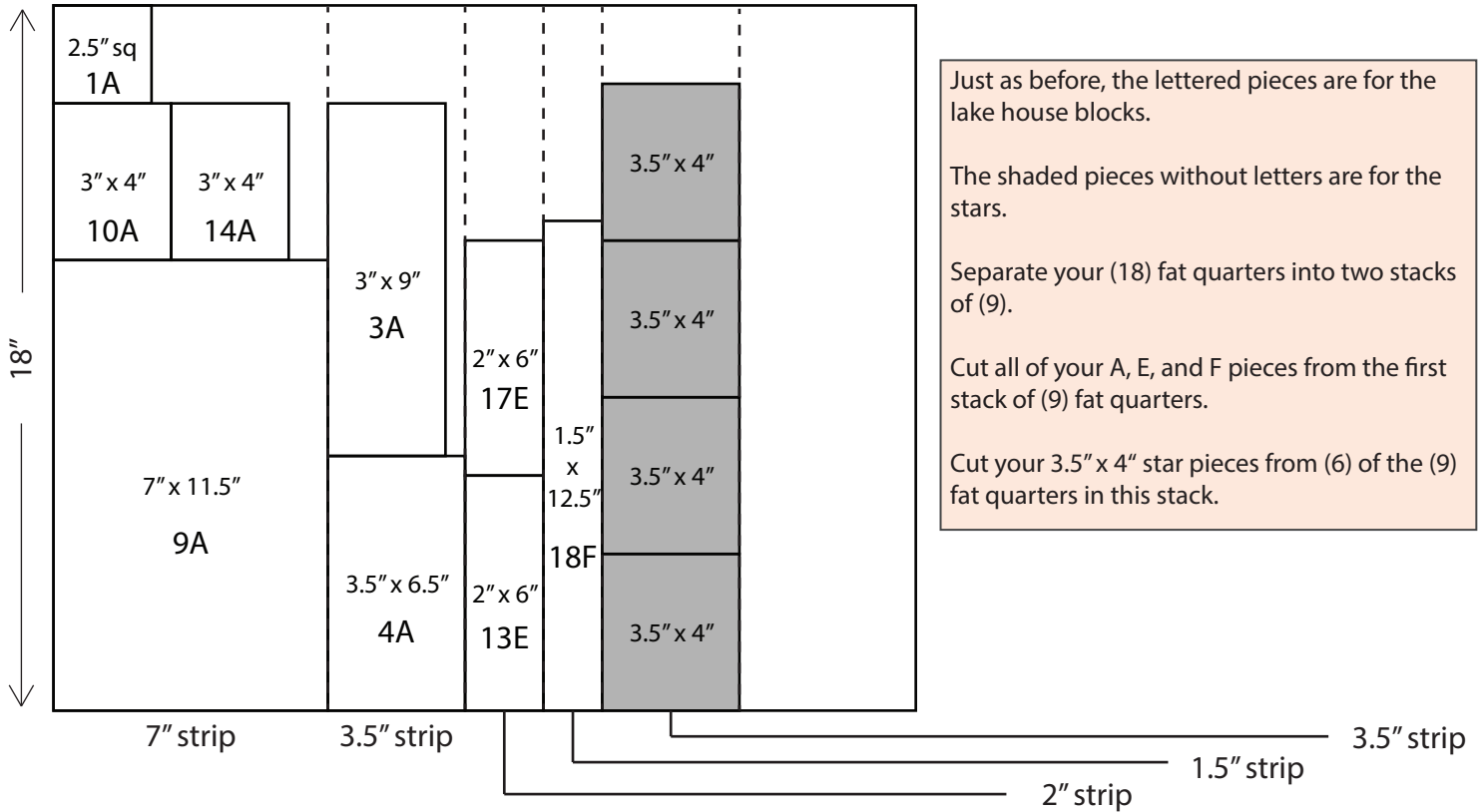

Just as before, the lettered pieces are for the lake house blocks.

The shaded pieces without letters are for the stars.

Separate your (18) fat quarters into two stacks of (9).

Cut all of your A, E, and F pieces from the first stack of (9) fat quarters.

Cut your 3.5" x 4" star pieces from (6) of the (9) fat quarters in this stack.

FQ's 10 - 18

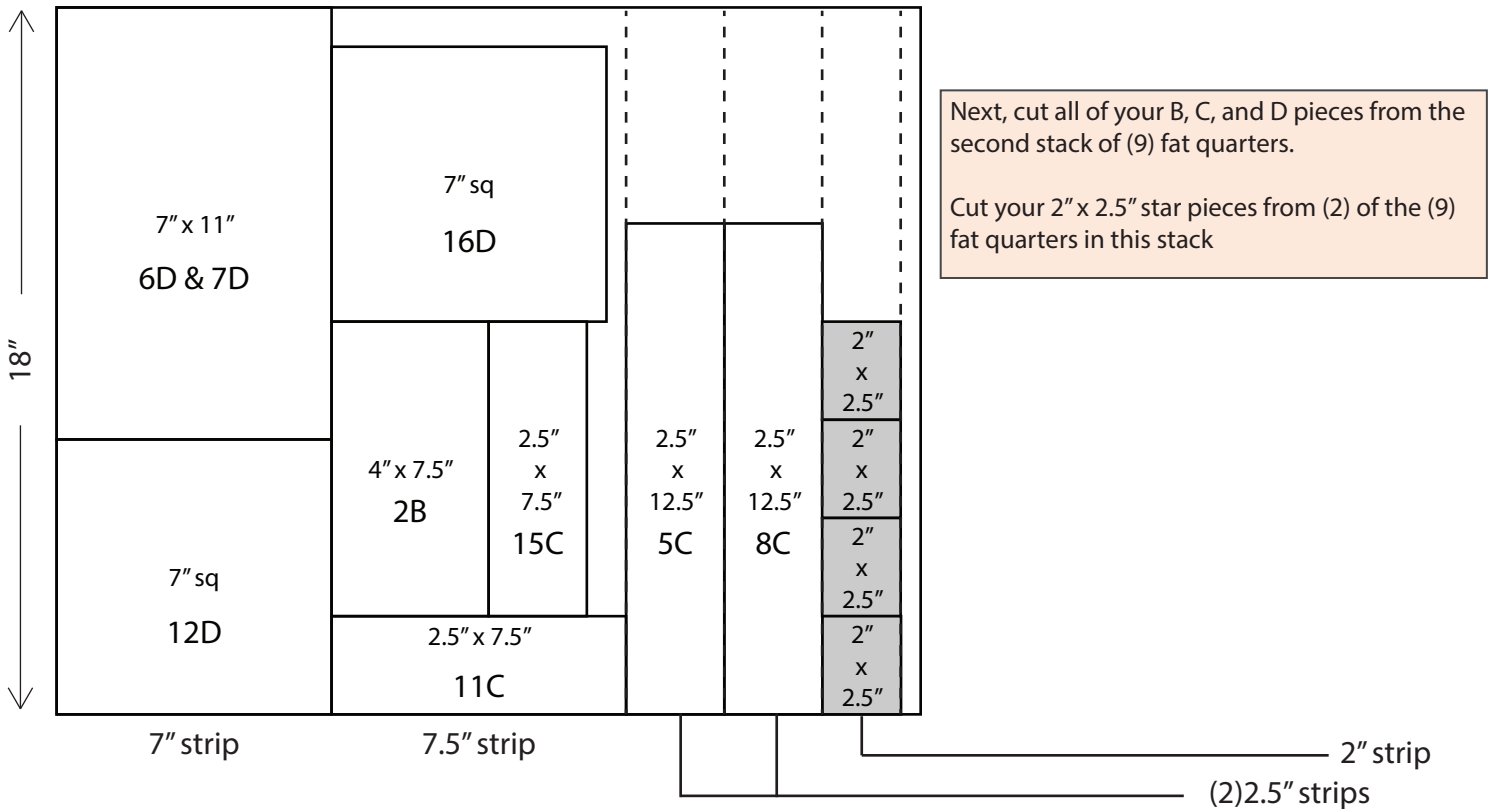

Next, cut all of your B, C, and D pieces from the second stack of (9) fat quarters.

Cut your 2" x 2.5" star pieces from (2) of the (9) fat quarters in this stack

Background Fabric Cutting Diagram

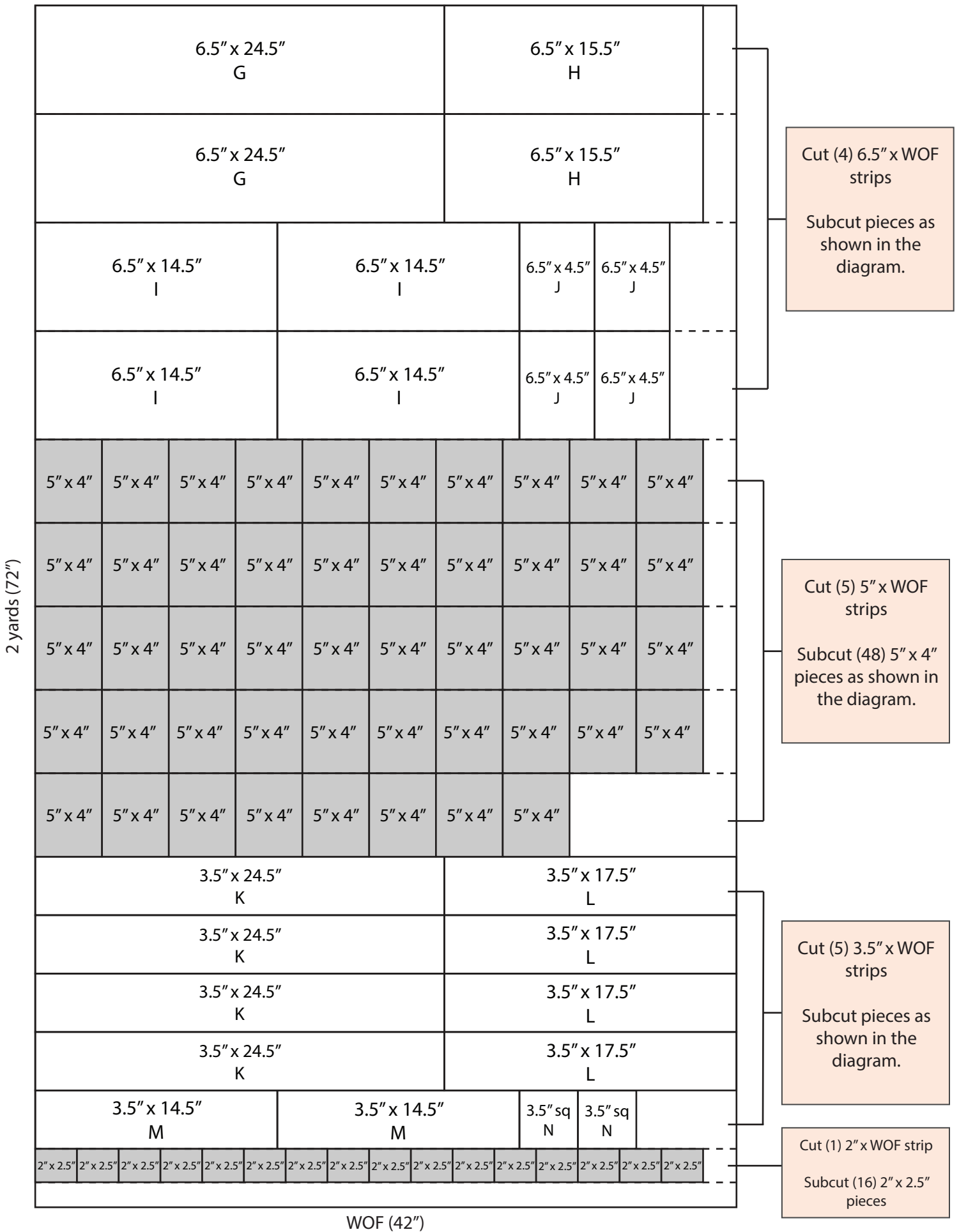

WOF (42")

Star Block Construction

Background Fabric

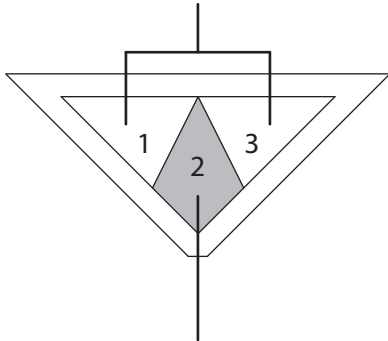

Each star is made up of four (4) identical sections.

For all stars, sew the pieces in the order shown to the left, starting with 1 and ending with 3.

Color/Print Fabric

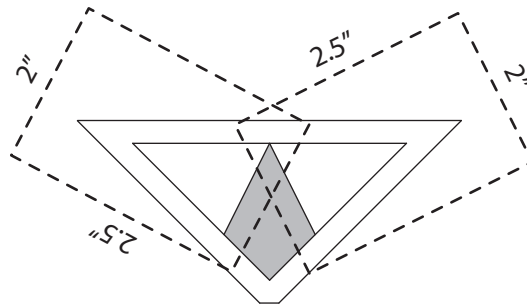
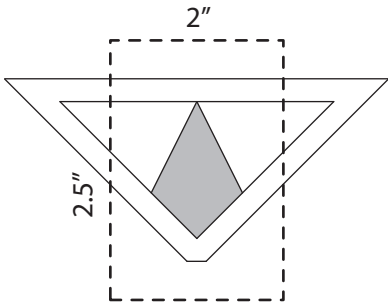

For the small stars, all of your cut pieces are the same dimensions (2" x 2.5").

The diagram to the left shows the orientation of the cut pieces when putting each section together.

For the center (color/print), cut piece should be attached vertically.

Background fabric pieces should be attached horizontally.

When you have (4) finished sections, attach (2) of them together as shown.

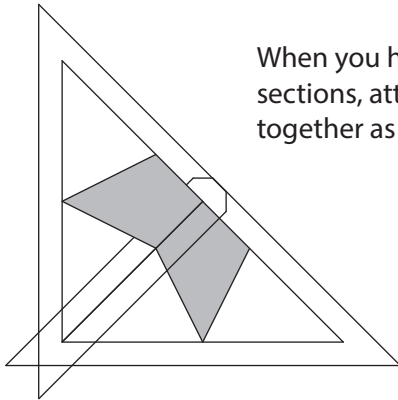

Attach the two pairs as shown.

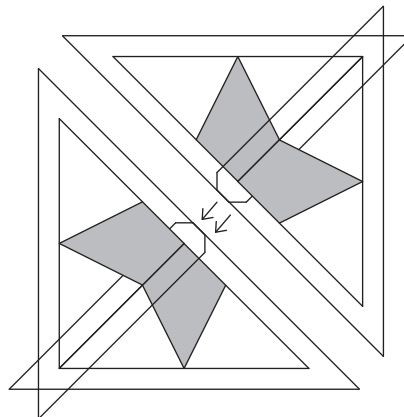

Quilt Construction Overview

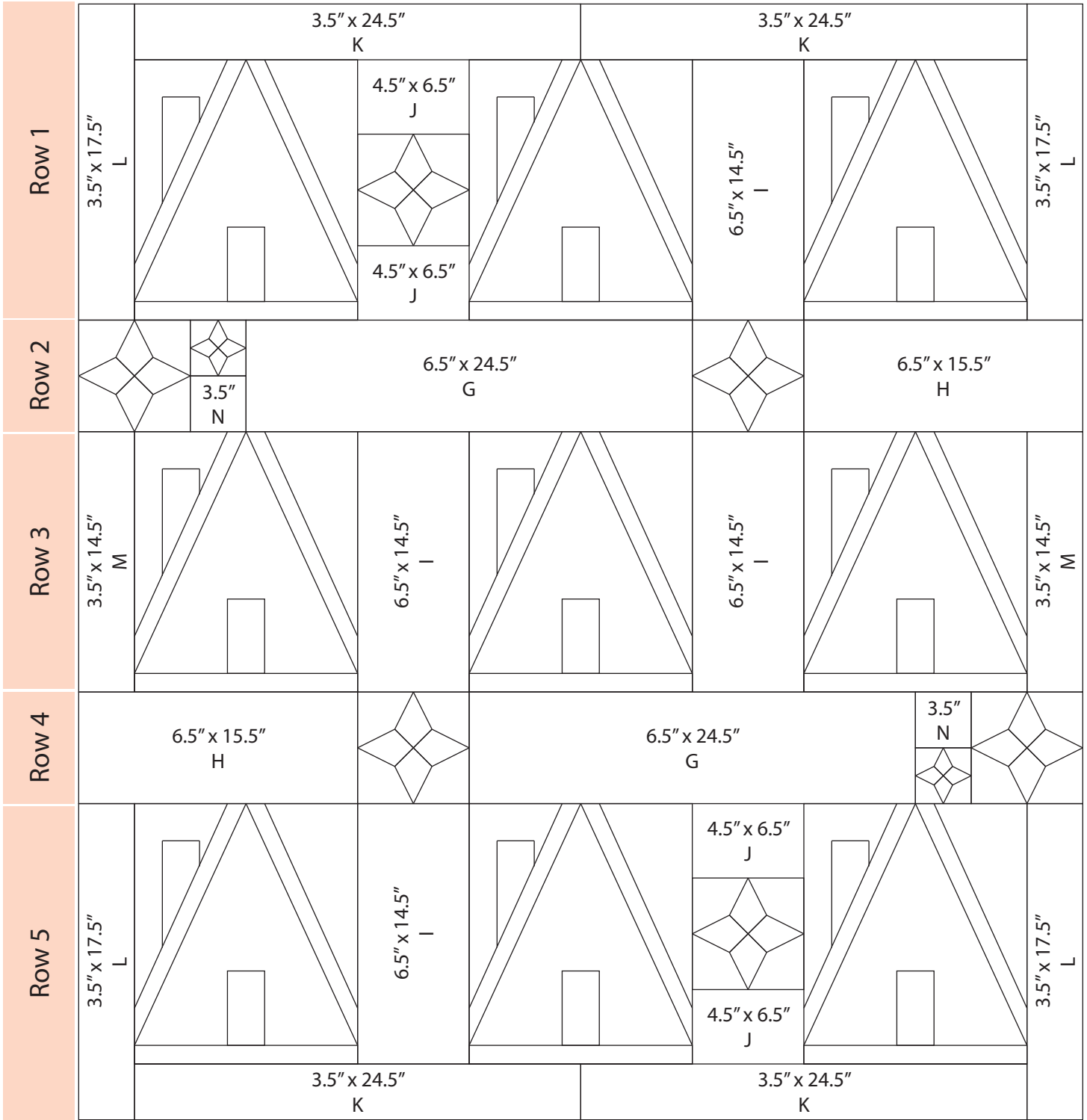

Row 1 Construction

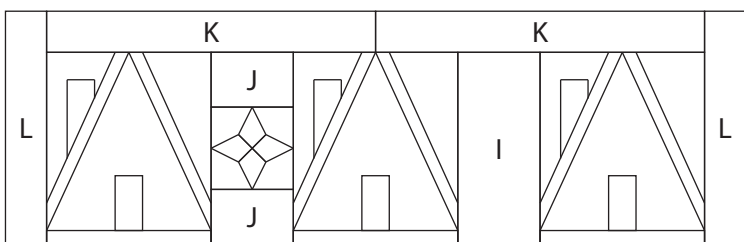
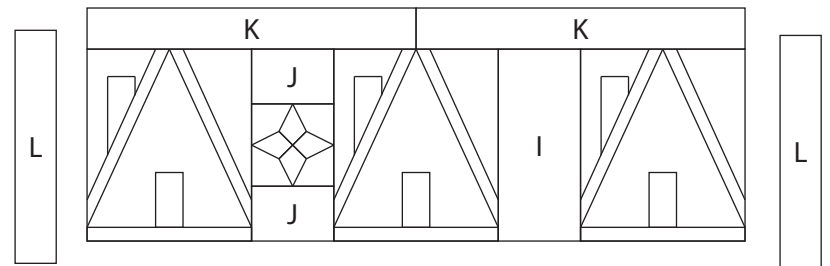
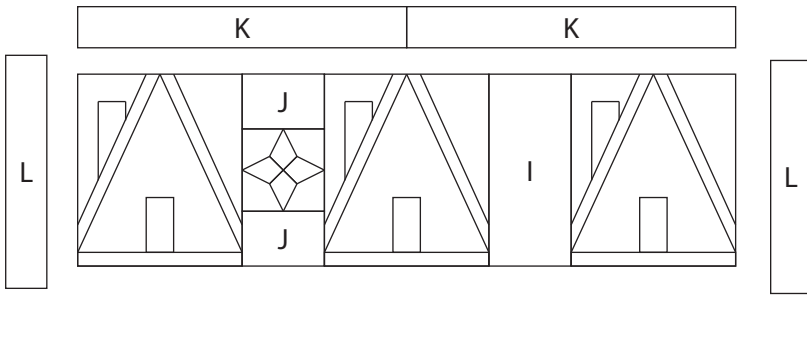
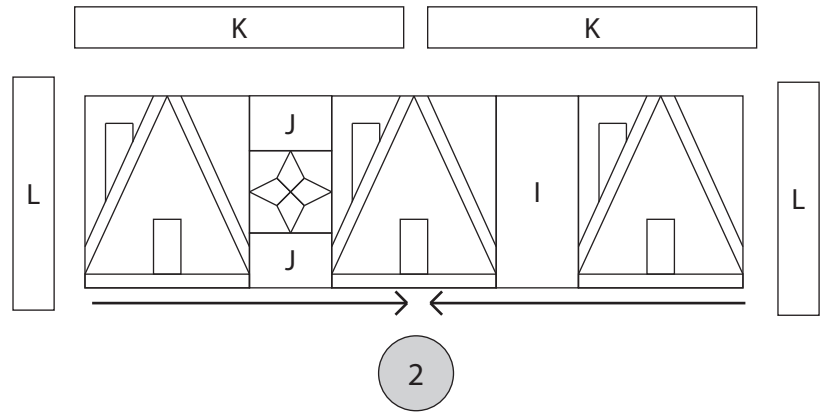
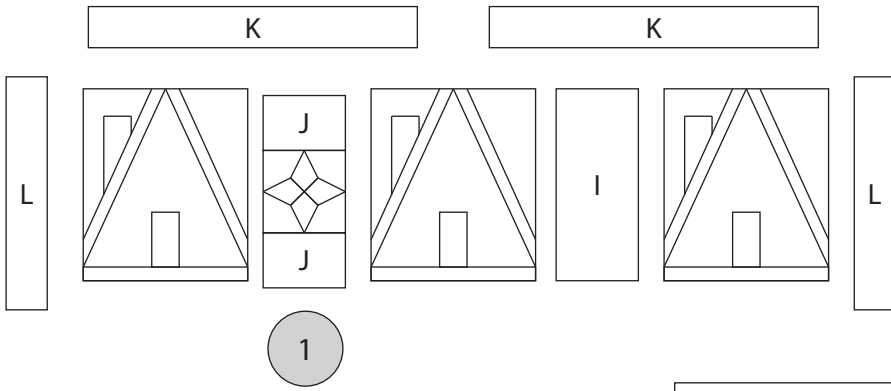

Row 2 Construction



1



2

Row 3 Construction

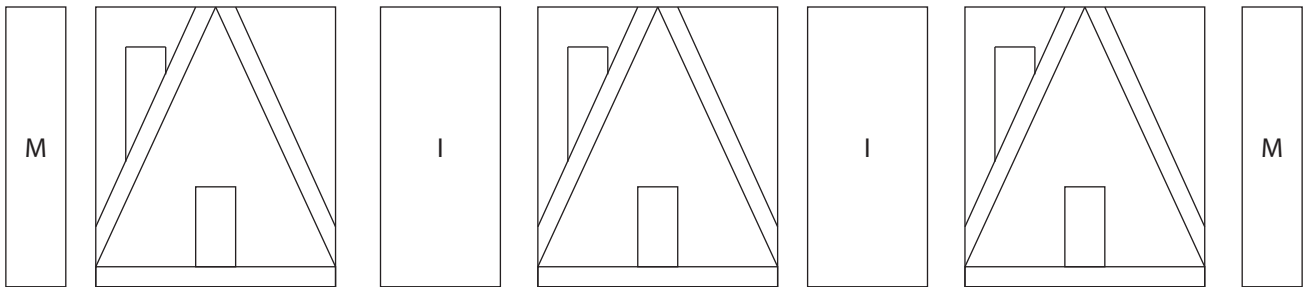

1

Row 4 Construction



1



2

Row 5 Construction

1

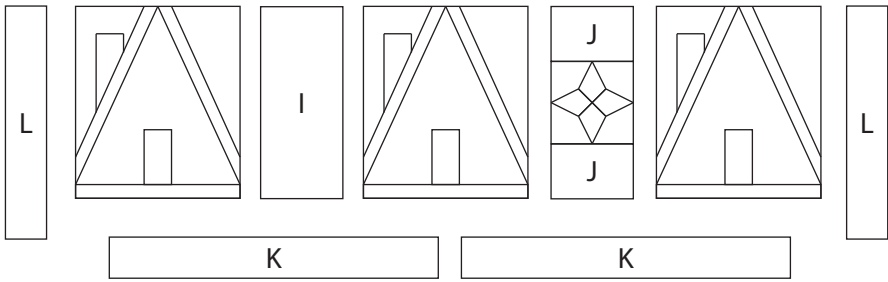

2

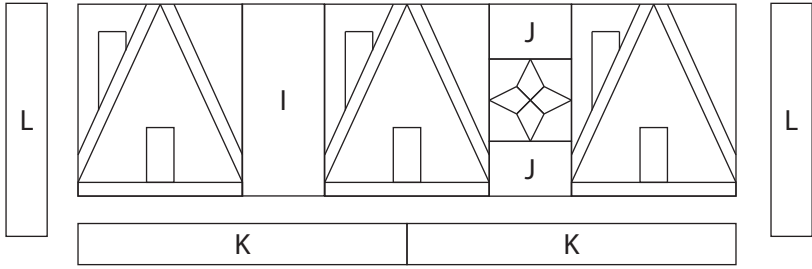
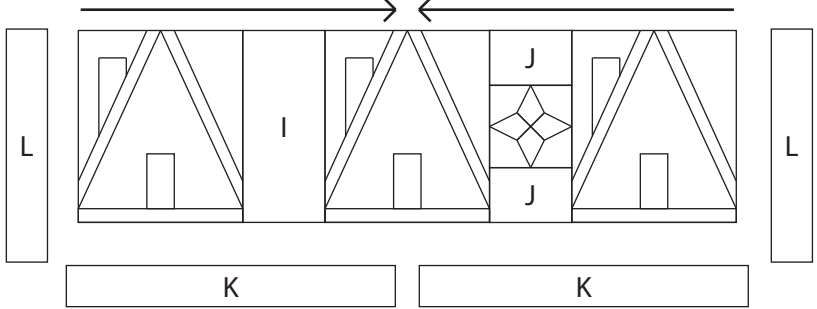

3

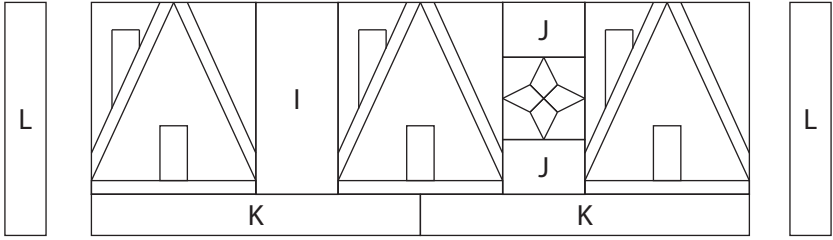

4

5

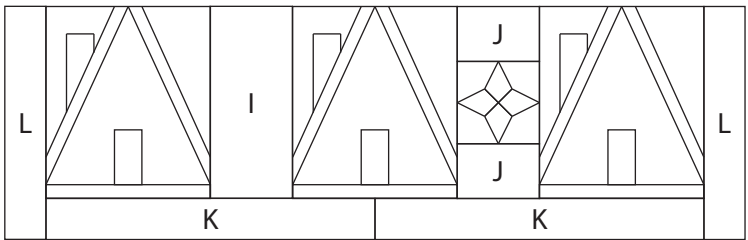

Coloring Page

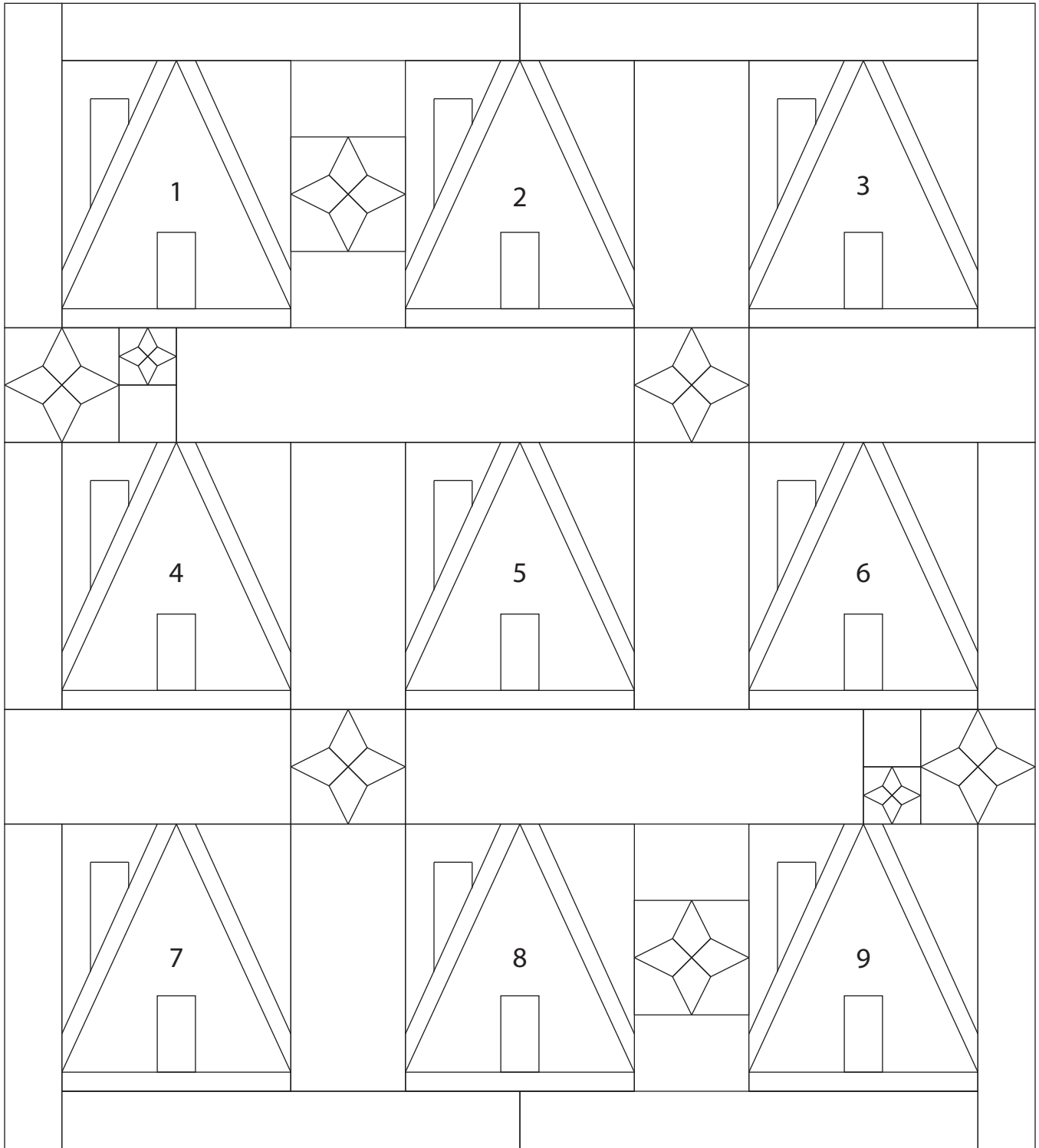

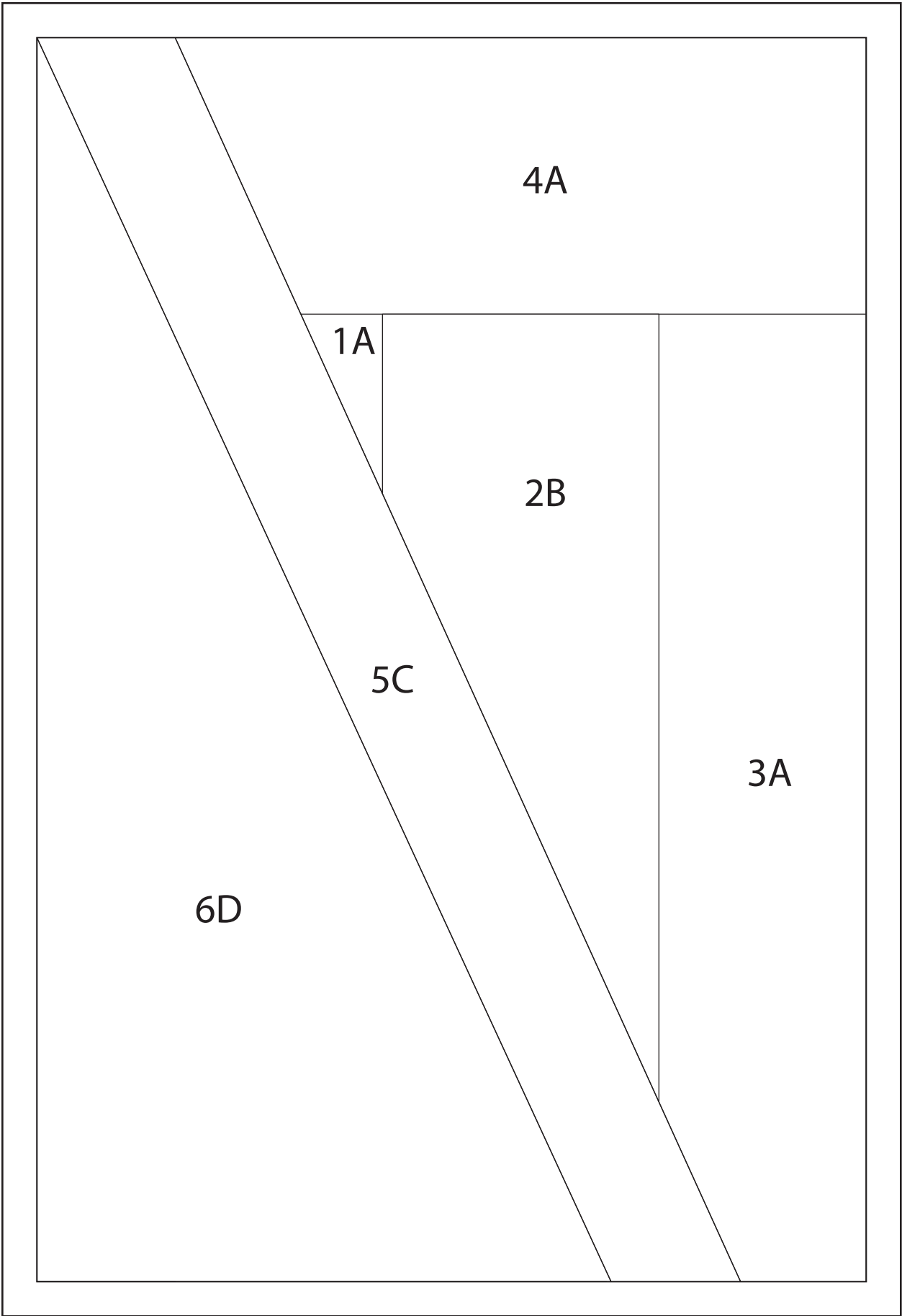

House Block Section 1 Template - Print (9) copies of this page at 100% Actual Size.

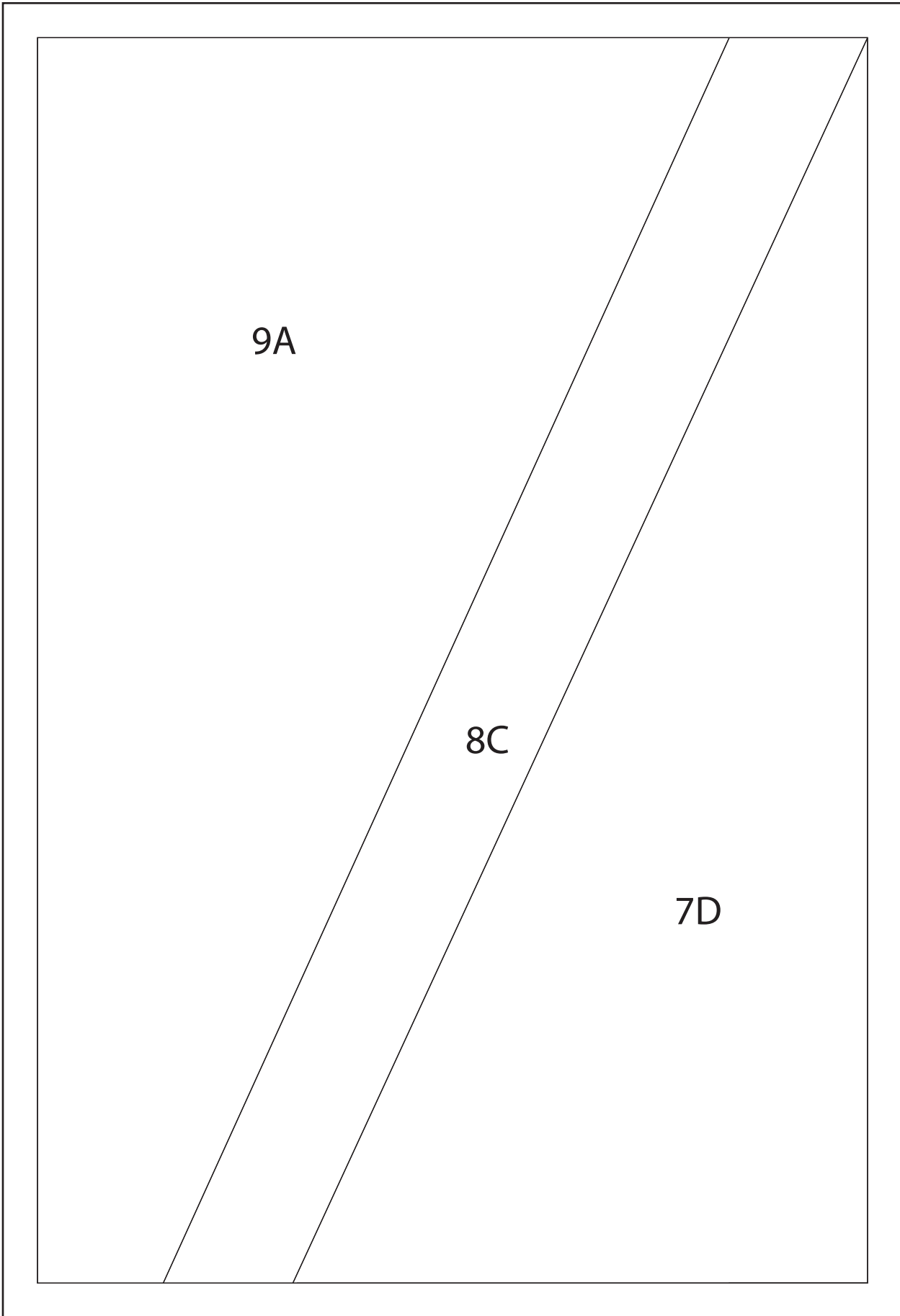

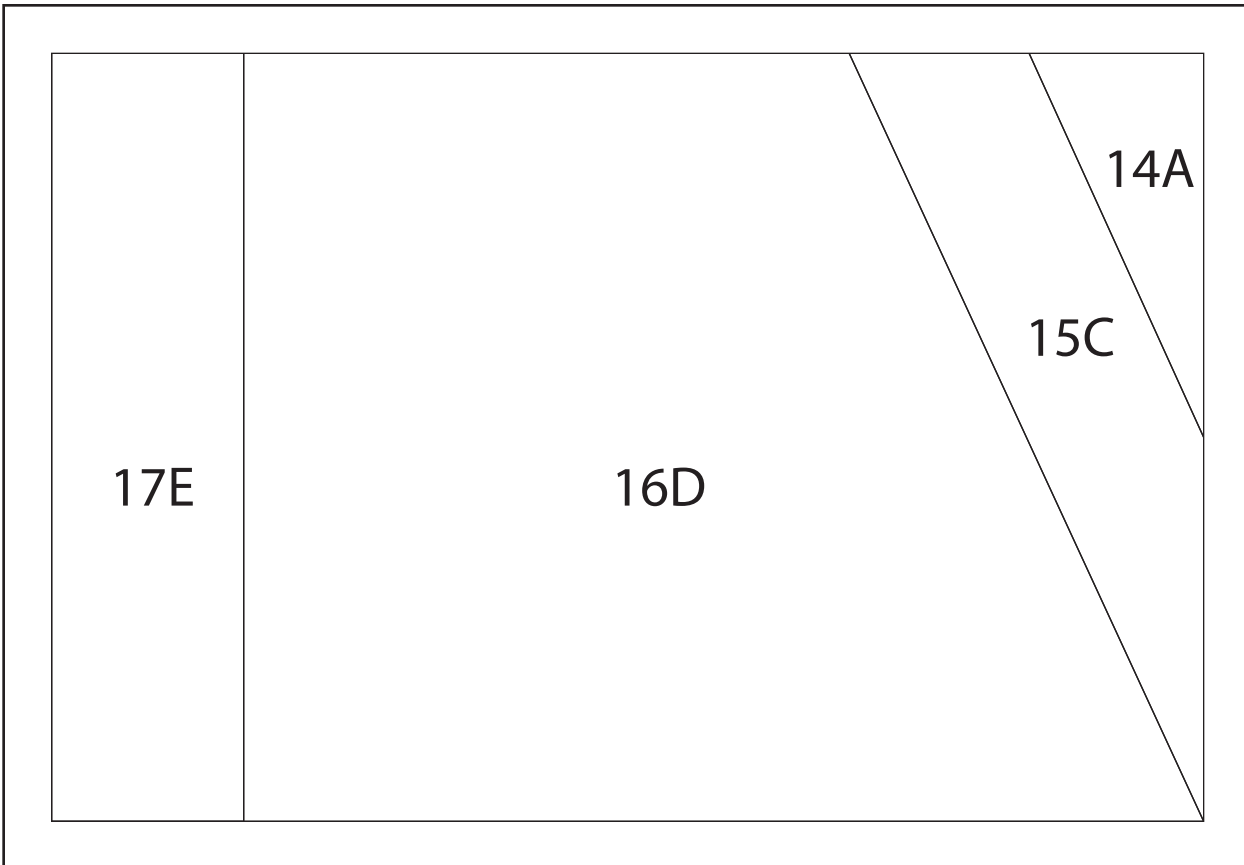
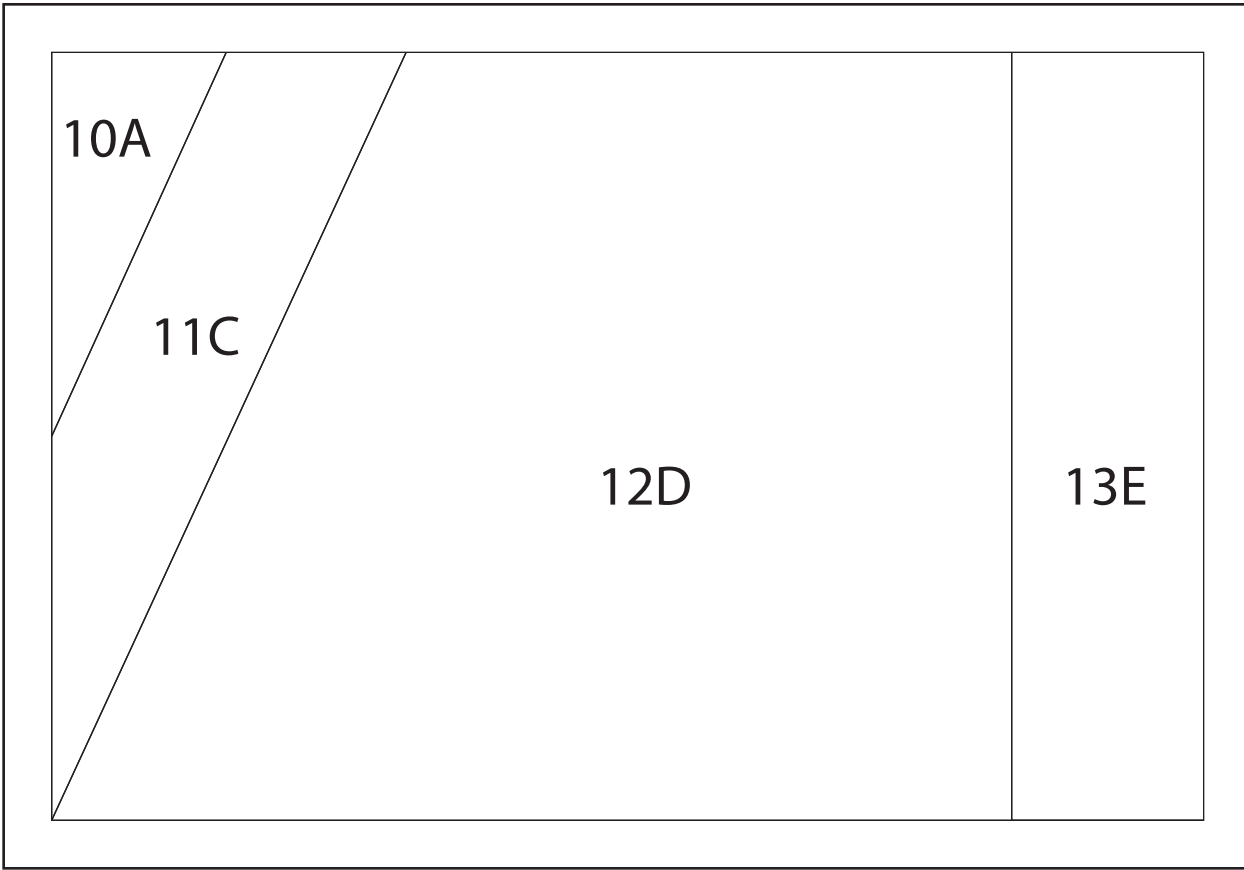

3.5" Star Print 2 - Make 2

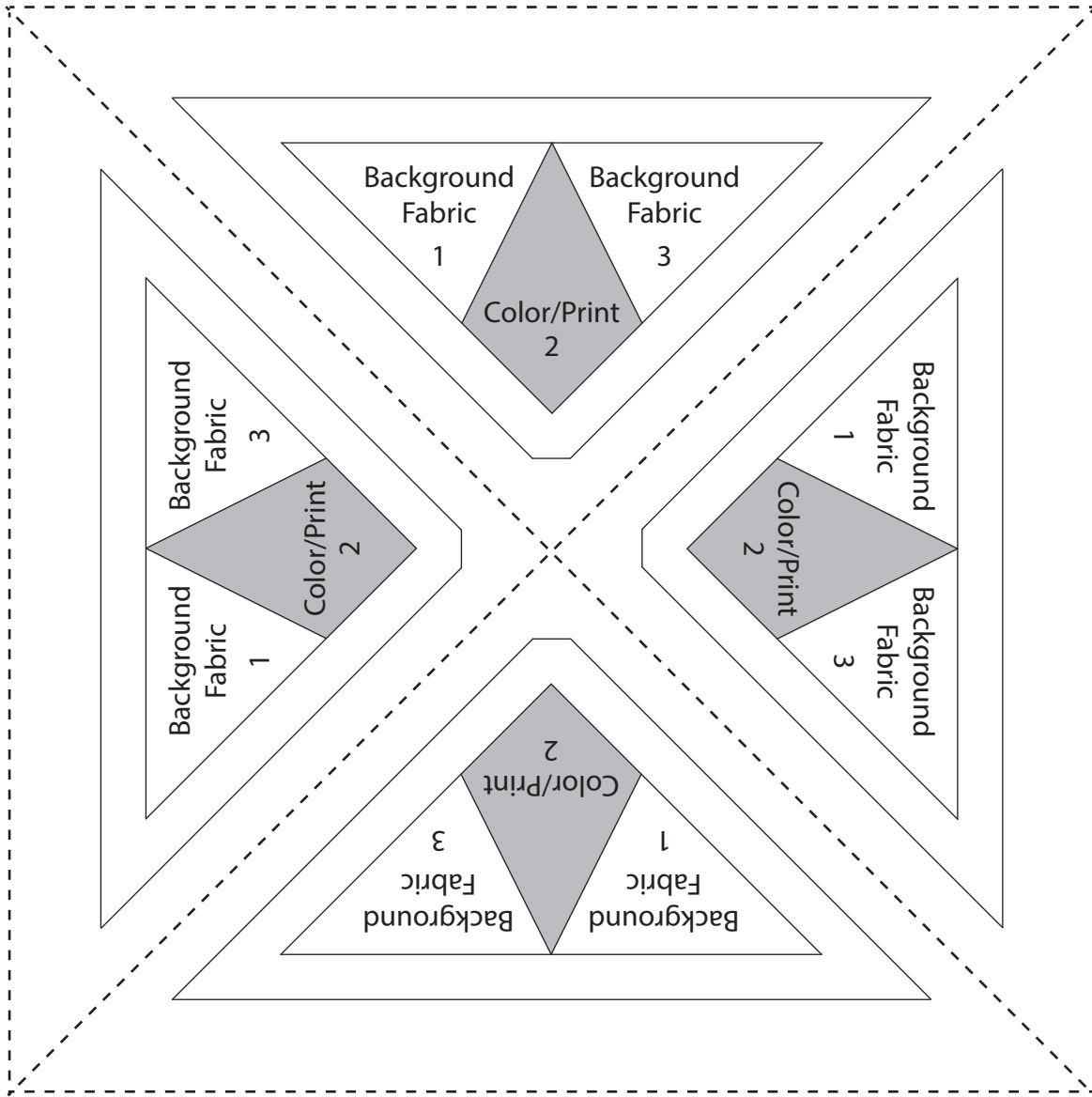

Instructions:

Cut along the dotted lines so that you have 4 pieces for each star.

Each printed page makes one star.

Be sure you are using the same color/print for each star (if that is your desired look).

Add each piece in order indicated, starting with 1, then 2, and then 3. The order should go: 1 - background, 2 - color/print, 3 - background.

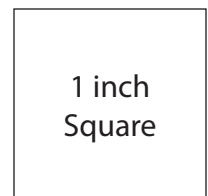

6.5" Star

Print 6 - Make 6

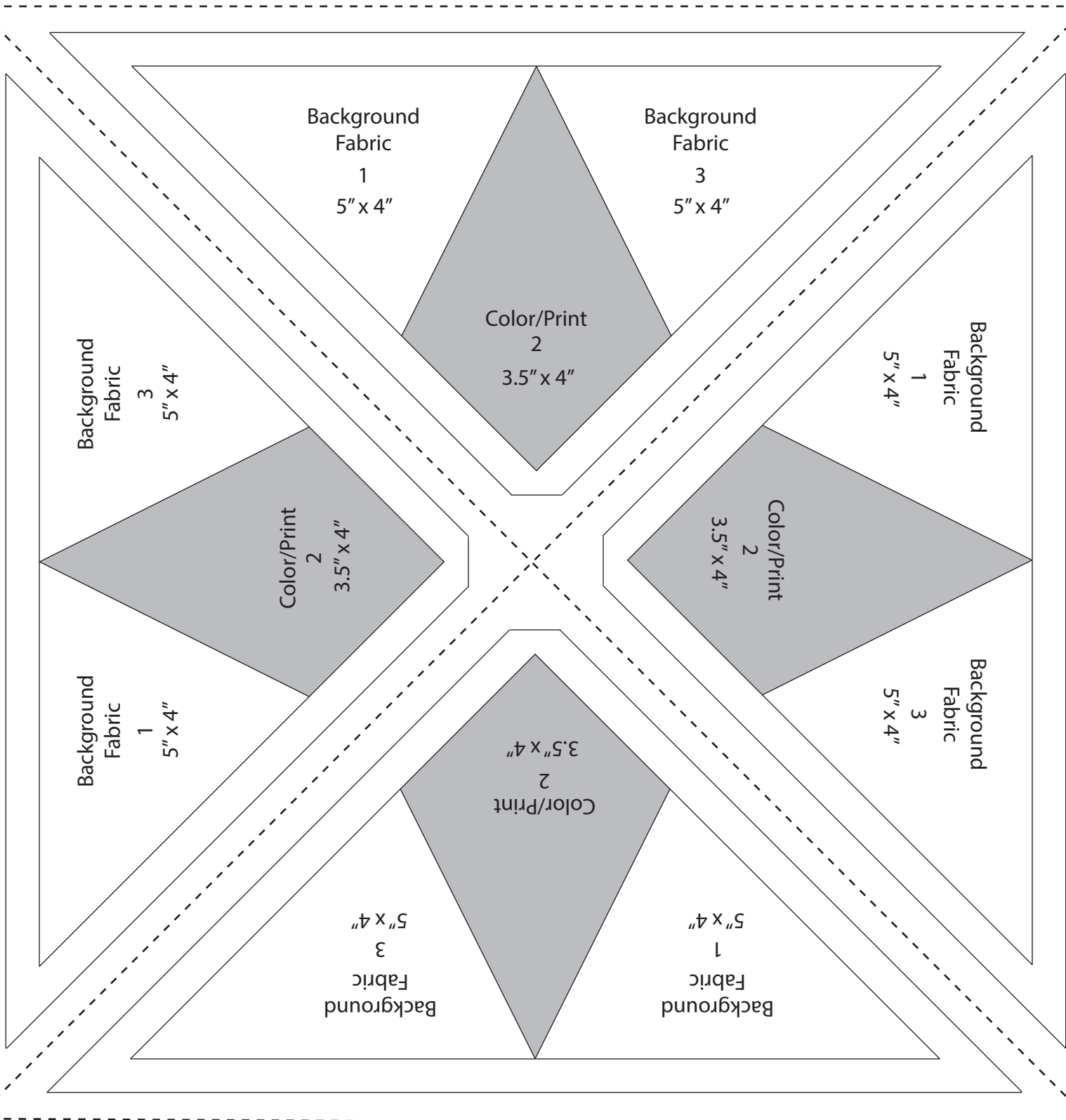

Instructions:

Same as with small stars.

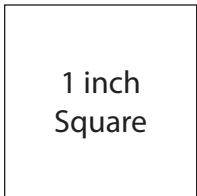

Labels

| | | | | | |
|-----------------------------|-----------------------------|-----------------------------|-----------------------------|-----------------------------|-----------------------------|
| House 1 Color/Print A | House 1 Color/Print B | House 1 Color/Print C | House 1 Color/Print D | House 1 Color/Print E | House 1 Color/Print F |
| House 2 Color/Print A | House 2 Color/Print B | House 2 Color/Print C | House 2 Color/Print D | House 2 Color/Print E | House 2 Color/Print F |
| House 3 Color/Print A | House 3 Color/Print B | House 3 Color/Print C | House 3 Color/Print D | House 3 Color/Print E | House 3 Color/Print F |
| House 4 Color/Print A | House 4 Color/Print B | House 4 Color/Print C | House 4 Color/Print D | House 4 Color/Print E | House 4 Color/Print F |
| House 5 Color/Print A | House 5 Color/Print B | House 5 Color/Print C | House 5 Color/Print D | House 5 Color/Print E | House 5 Color/Print F |
| House 6 Color/Print A | House 6 Color/Print B | House 6 Color/Print C | House 6 Color/Print D | House 6 Color/Print E | House 6 Color/Print F |
| House 7 Color/Print A | House 7 Color/Print B | House 7 Color/Print C | House 7 Color/Print D | House 7 Color/Print E | House 7 Color/Print F |
| House 8 Color/Print A | House 8 Color/Print B | House 8 Color/Print C | House 8 Color/Print D | House 8 Color/Print E | House 8 Color/Print F |
| House 9 Color/Print A | House 9 Color/Print B | House 9 Color/Print C | House 9 Color/Print D | House 9 Color/Print E | House 9 Color/Print F |